

TECH
NOTE

X-10 Communications Protocol
and
Power Line Interface
PSC04 & PSC05

REV 2.4



PSC04/PSC05 Power Line Interfaces Introduction

The X-10 PRO code format is the "De Facto" standard for Power Line Carrier (P.L.C.) transmission. The code format was first introduced in 1978 for the Sears Home Control System and the Radio Shack Plug 'n Power System. Since then, X-10 PRO has developed and manufactured O.E.M.* versions of its Home Control System for many companies including IBM, Leviton Manufacturing Co., General Electric, RCA, Philips, Stanley and Leviton. We also distribute the system in Canada and have manufactured OEM versions of the system for Germany, Holland, France, Switzerland, Japan and Australia.

All of these systems use the X-10 PRO code format, all are compatible and virtually all P.L.C. Home Automation Systems currently available in the USA use X-10 PRO Modules developed and manufactured by X-10 PRO. It is therefore advantageous for any Home Automation System to be compatible with the X-10 PRO standard. This enables any O.E.M. to take advantage of the very large installed base of X-10 PRO customers as well as having access to the extensive array of different types of X-10 PRO Modules available.

The X-10 PRO code format is patented

However, in order to encourage others to take advantage of the large installed base of X-10 PRO Modules and develop their own systems to control these Modules, the PSC04 and PSC05 Power Line Interfaces are offered as cost effective ways of coupling X-10 PRO compatible signals onto the AC power line. Permission to transmit the X-10 PRO code format is granted to purchasers of the PSC04 and PSC05 Power Line Interfaces.

The PSC04 is a transmitter and the PSC05 is a transmitter-receiver. Both plug into regular AC outlets and connect to the OEM product via a modular RJ11 telephone jack. Both interfaces provide an opto-coupled 60 Hz square wave, synchronized to the zero crossing point of the AC line. The OEM generates X-10 PRO compatible codes synchronized to this zero crossing point. The PSC04 and PSC05 then couple the X-10 PRO codes onto the AC line. Thus all patent related criteria are satisfied within the interfaces.

This also relieves the OEM of any U.L. or C. S. A. considerations as all power line connections are taken care of by the interfaces and all connections between the interfaces and the OEM product are opto-coupled.

Two-Way transmission available

The PSC05 is similar in concept and design to the PSC04 but provides a means to transmit *and* receive X-10 PRO codes. Any OEM product designed to receive X-10 PRO codes MUST use the PSC05. X-10 PRO will not grant permission to receive X-10 PRO codes by any other method.

The PSC05 enables an OEM to develop a system to control X-10 PRO Modules, and receive X-10 PRO signals from remote sensors (P.I.R. motion detectors for example).

The PSC05 lets the OEM transmit a "polling" code to the PAT01 2-Way Transceiver Appliance Module. The PAT01 responds by transmitting a specific code to indicate its status (on or off). The PSC05 then receives this code. When used with the PAT01, the PSC05 gives the O.E.M. the ability to implement a full 2-Way system with collision detection and contention resolution. Other X-10 PRO bi-directional Products include: PLM21 Two-way Lamp Module, PAM21 and PAM22 Two-way 15A Appliance Module (2 pin and 3 pin)

X-10 PRO Code Transmission (PSC04 and PSC05)

To transmit X-10 PRO signals the OEM must supply 1 ms "envelopes" to the TX input of the interface with respect to common. These envelopes must be as close as possible to the zero crossing point of the AC line (see timing diagrams). An opto-coupled output representing the zero crossing point of the power line is provided for the OEM to which X-10 PRO codes are to be synchronized.

* **O.E.M. = Original Equipment Manufacturer.**

X-10 PRO Code Reception (PSC05 only)

The PSC05 uses a custom proprietary IC to read X-10 PRO codes from the power line. This takes a lot of burden off the microprocessor in the OEM product as the O.E.M. microprocessor does not have to continuously monitor the power line and check all incoming signals (and noise) for validity. Any signals applied to the OEM product are error-checked, valid X-10 PRO codes. When a valid X-10 PRO code is received, it is stored in the custom IC and applied (in envelope form) to the O.E.M. product. This output is coincident with the second X-10 PRO transmission. (X-10 PRO codes are always transmitted in groups of two, except for Bright and Dim see note 3, page 5).

Data sent to the OEM product is valid X-10 PRO data. The Start Code (1110) can be used to alert the OEM product that an X-10 PRO code will follow. A "1" bit from the PSC05 appears as a negative going pulse 1.1 ms long, beginning approximately 100 ms after zero crossing. The OEM should sample this data between 500 and 700 ms after zero crossing.

The LED on the PSC05 gives a visual indication that X-10 PRO codes are being received. The LED is illuminated when AC power is applied to the PSC05, and blinks off when X-10 PRO codes are received. The PSC05 will also receive the codes it transmits, therefore the LED will also give an indication of codes being transmitted.

The ability to read X-10 PRO codes from its own output also allows the OEM to incorporate data collision detection. If the code received differs from the code transmitted, the code can be assumed to have been corrupted by noise (or another transmission) on the power line.

The Line Monitor capability of the PSC05 allows the OEM to ensure that the power line is free from X-10 PRO signals before starting a transmission. This means that in a multi-transmitter system the OEM can minimize contention between transmitters. For example, if after detecting that the line is free, a transmitter waits for a random number of power line half cycles before transmitting, the chance of collision is reduced. A different priority can be assigned to each transmitter by including a fixed delay before the random delay. The shorter the fixed delay, the higher the priority.

Important Safety Notice

OV In this product is directly connected to one side of the AC line. Therefore, for safety, an ISOLATING power transformer MUST be Used when attempting any Internal measurements.

The power supplies in the PSC04 and PSC05 are capacitively derived from, and directly referenced to, the 120 volt AC power line. Care should be taken when monitoring any internal circuitry with an oscilloscope, as the 0 V reference in the PSC04 and PSC05 are NOT isolated from 120 volts.

X-10 PRO transmissions are synchronized to the zero crossing point of the AC power line. The design goal should be to transmit as close to the zero crossing point as possible but certainly within 200 microseconds of the zero crossing point. The PSC04 and PSC05 provide a 60 Hz. square wave with a max. delay of 100 micro seconds from the zero crossing point of the AC power line. The maximum delay between signal envelope input and 120KHz. output bursts is 50 micro seconds. Therefore, it should be arranged that outputs to the PSC04 and PSC05 be within 50 micro seconds of this 60 Hz. zero crossing reference square wave.

A Binary 1 is represented by a 1 millisecond burst of 120 KHz. at the zero crossing point and a Binary 0 by the absence of 120 KHz. The PSC04 and PSC05 modulate their inputs (from the OEM) with 120KHz., therefore only the 1 ms "envelope" need be applied to their inputs. These 1 millisecond bursts should actually be transmitted three times to coincide with the zero crossing points of all three phases in a three phase distribution system. Figure 1 shows the timing relationship of these bursts relative to zero crossing.

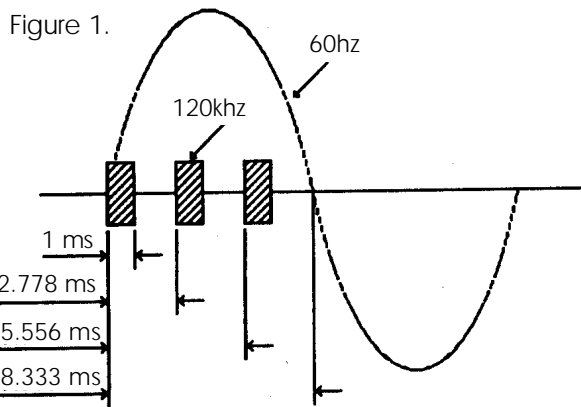

Note. - For clarity, the signals in figure 1 are shown as they would be seen through a high pass filter. The 60 Hz. waveform is only shown for reference. In reality the signals are actually superimposed on the 60 Hz. waveform and look more like that shown in figure 2.

A complete code transmission encompasses eleven cycles of the power line. The first two cycles represent a Start Code. The next four cycles represent the House Code and the last five cycles represent either a Number Code (1 thru 16) or a Function Code (On, Off etc.). This complete block, (Start Code, House Code, Key Code) should always be transmitted in groups of 2 with 3 power line cycles between each group of 2 codes. Bright and dim are exceptions to this rule and should be transmitted continuously (at least twice) with NO gaps between codes. See figure 3.

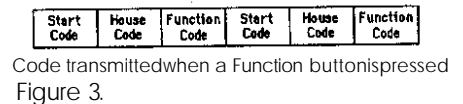
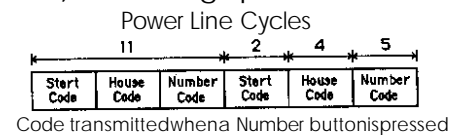
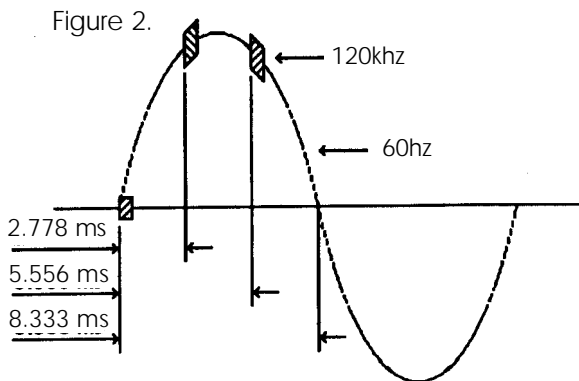

Within each block of data, each four or five bit code should be transmitted in true and complement form on alternate half cycles of the power line. i.e. if a 1 millisecond burst of signal is transmitted on one half cycle, (binary 1) then no signal should be transmitted on the next half cycle, (binary 0). See Figure 4 below.

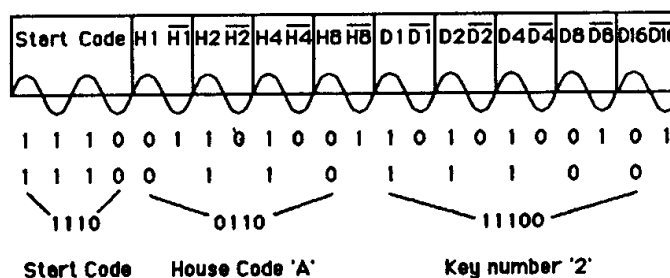

The Tables in figure 5. show the Binary Codes to be transmitted for each House Code and Key Code. The Start Code is always 1110 which is a unique code and is the only code which does not follow the true complement relationship on alternate half cycles.

Figure 5.
House Code and Key Code Tables.

House Codes				Key Codes						
	H1	H2	H4	H8	D1	D2	D4	D8	D16	
A	0	1	1	0	1	0	1	1	0	0
B	1	1	1	0	2	1	1	1	0	0
C	0	0	1	0	3	0	0	1	0	0
D	1	0	1	0	4	1	0	1	0	0
E	0	0	0	1	5	0	0	0	1	0
F	1	0	0	1	6	1	0	0	1	0
G	0	1	0	1	7	0	1	0	1	0
H	1	1	0	1	8	1	1	0	1	0
I	0	1	1	1	9	0	1	1	1	0
J	1	1	1	1	10	1	1	1	1	0
K	0	0	1	1	11	0	0	1	1	0
L	1	0	1	1	12	1	0	1	1	0
M	0	0	0	0	13	0	0	0	0	0
N	1	0	0	0	14	1	0	0	0	0
O	0	1	0	0	15	0	1	0	0	0
P	1	1	0	0	16	1	1	0	0	0
				All Units Off	0	0	0	0	1	
				All Lights On	0	0	0	1	1	
				On	0	0	1	0	1	
				Off	0	0	1	1	1	
				Dim	0	1	0	0	1	
				Bright	0	1	0	1	1	
				All Lights Off	0	1	1	0	1	
				Extended Code	0	1	1	1	1	
				Hail Request	1	0	0	0	1	1
				Hail Acknowledge	1	0	0	1	1	
				Pre-Set Dim	1	0	1	X	1	2
				Extended Data (analog)	1	1	0	0	1	3
				Status = on	1	1	0	1	1	
				Status = off	1	1	1	0	1	
				Status Request	1	1	1	1	1	

1 Hail Request is transmitted to see if there are any other X-10 PRO transmitters within listening range. This allows the OEM to assign a different Housecode if a "Hail Acknowledge" is received.

2 In a Pre-Set Dim instruction, the D8 bit represents the Most Significant Bit of the level and H1, H2, H4 and H8 bits represent the 4 Least Significant bits

3 The Extended Data code is followed by 8 bit bytes which can represent Analog Data (after A to D conversion). There should be no gaps between the Extended Data code and the actual data, and no gaps between data bytes. The first 8 bit byte can be used to say how many bytes of data will follow. If gaps are left between data bytes, these codes could be received by X-10 PRO Modules causing erroneous operation.

Extended Code is similar to Extended Data: 8 Bit bytes which follow Extended Code (with no gaps) can represent additional codes. This allows the designer to expand beyond the 256 codes currently available

IMPORTANT NOTES

NOTE 1. X-10 PRO Receiver Modules require a "silence" of at least 3 power line cycles between each pair of 11 bit code transmissions (no gaps between each pair). The one

exception to this rule is bright and dim codes. These are transmitted continuously with no gaps between each 11 bit dim code or 11 bit bright code. A 3 cycle gap is necessary between different codes, i.e., between bright and dim, or 1 and dim, or on and bright, etc.

NOTE 2. The PSC05 Two-Way Power Line Interface cannot receive Extended Code or Extended Data because these codes have no gaps between them. The PSC05 can only receive standard "pairs" of 11 bit X-10 PRO codes with 3 power line cycle gaps between each pair.

NOTE 3. The PSC05 can receive dim and bright codes but the output will represent the first dim or bright code received, followed by every third code received. i.e. the output from the PSC05 will not be a continuous stream of dim or bright codes like the codes which were transmitted.

Transmission Timing Diagrams.

A square wave representing zero crossing detect is provided by the PSC04/PSC05 and is within 100 ms of the zero crossing point of the AC power line. The output signal envelope from the OEM should be within 50 ms of this zero crossing detect. The signal envelope should be 1 ms (-50ms +100ms). See Figure 6.

Opto-Coupled 60 Hz. reference output (from the PSC04/PSC05)

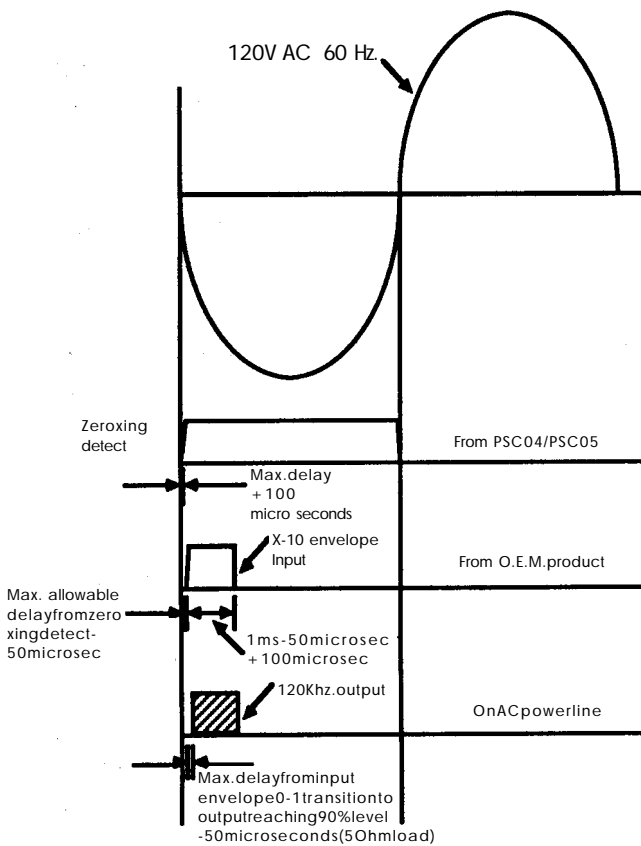

Figure 6. Transmit Timing Diagrams.

Transmissions are to be synchronized to the zero crossing point of the AC power line and should be as close to true zero crossing as possible. The PSC04 and PSC05 are designed to be interfaced to other microprocessor circuitry which outputs X-10 PRO codes synchronized to the zero crossing point of the AC power line. It is therefore necessary to provide a zero crossing reference for the OEM microprocessor.

It is likely that this microprocessor will have its own "isolated" power supply. It is necessary to maintain this isolation, therefore the trigger circuit normally used in X-10 PRO controllers is not desirable as this would reference the OEM power supply to the AC power line. It is also not desirable to take the trigger from the secondary side of the power supply transformer as some phase shift is likely to occur. It is therefore necessary to provide an optocoupled 60 Hz. reference.

An opto-coupled 60 Hz. square wave is provided at the output of the PSC04 and PSC05. X-10 PRO codes generated by the OEM product are to be synchronized to this zero crossing reference. The X-10 PRO code envelope generated by the OEM is applied to the PSC04 or PSC05 which modulates the envelope with 120 KHz. and capacitively couples it to the AC power line.

Opto-Coupled Signal Input (to the PSC04/PSC05)

The input signal required from the OEM product is the signal "envelope" of the X-10 PRO code format, i.e.

High for 1 ms. coincident with zero crossing represents a binary "1" and gates the 120 KHz. oscillator through to the output drive circuit thus transmitting 120 KHz. onto the AC power line for 1 ms.

Low for 1 ms. coincident with the zero crossing point represents a binary "0" and turns the 120 KHz. oscillator/output circuit off for the duration of the 1 ms input.

Opto-Coupled Signal Output (from the PSC05)

The "X-10 PRO received" output from the PSC05 coincides with the second half of each X-10 PRO transmission. This output is the envelope of the bursts of 120 KHz. received. Only the envelope corresponding to the first burst of each group of 3 bursts is available at the output of the PSC05. See figures 7, 8 and 9.

X-10 code received from the AC power line.

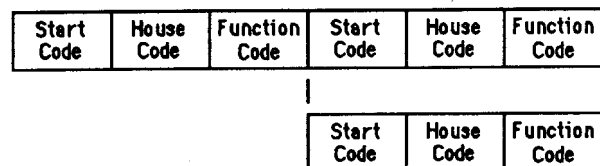

Figure 7.

"X-10 received" output from PSC05

Receive Timing Diagrams

Figure 8.

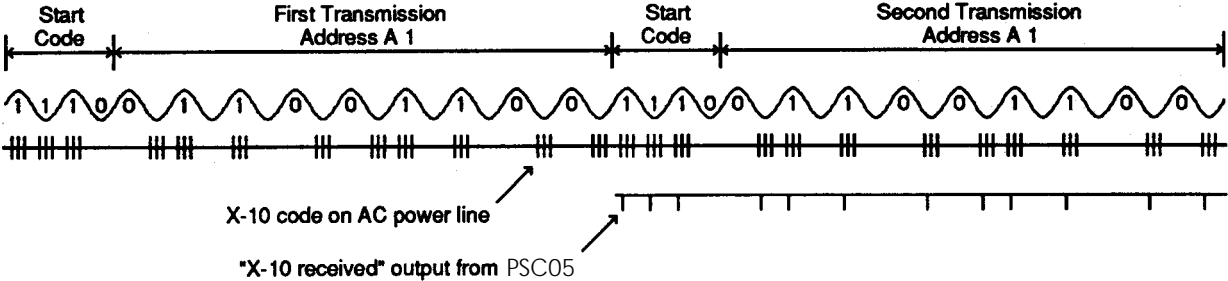
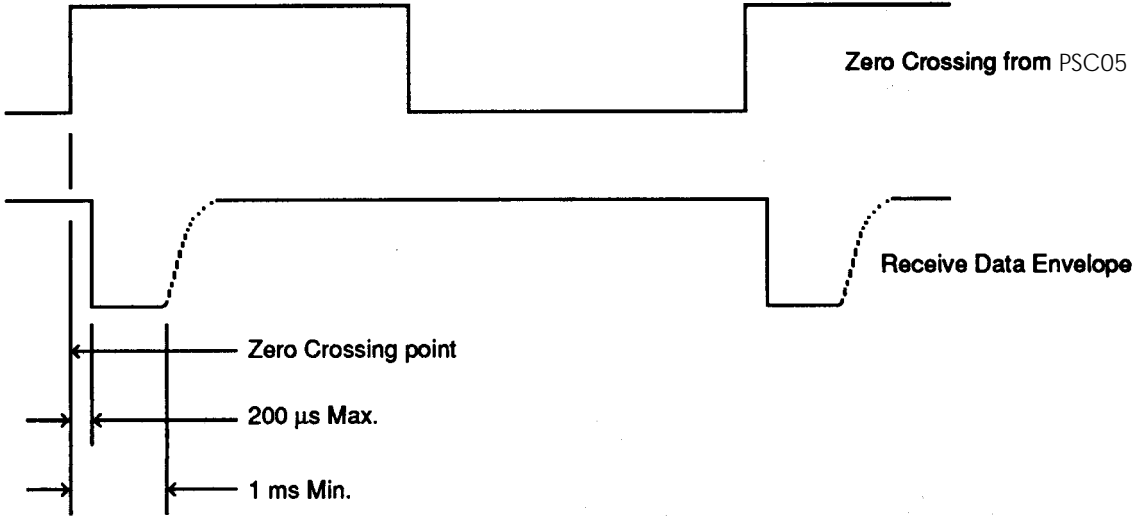

Figure 9.



PSC04 Block Diagram

Connection between the OEM product is via a standard modular phone jack, the connections for which are as follows:

1. B Zero crossing detect output (with respect to 2).
2. R Zero crossing detect common.
3. G X-10 transmit envelope common.
4. Y X-10 transmit envelope input (with respect to 3).

PSC05 Block Diagram

Connection between the OEM product is via a standard modular phone jack, the connections for which are as follows:

1. B Zero crossing detect output (with respect to 2).
2. R Common.
3. G X-10 received envelope output.
4. Y X-10 transmit envelope input (with respect to 2).

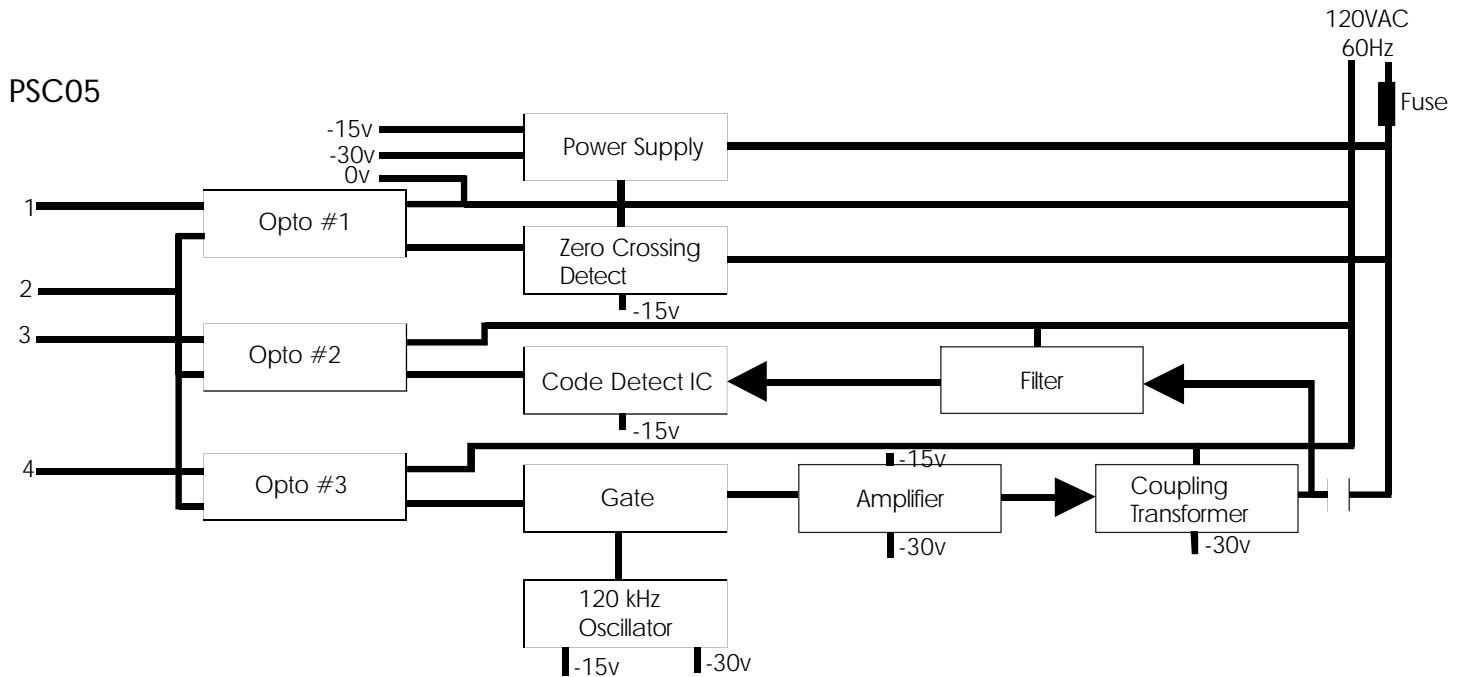
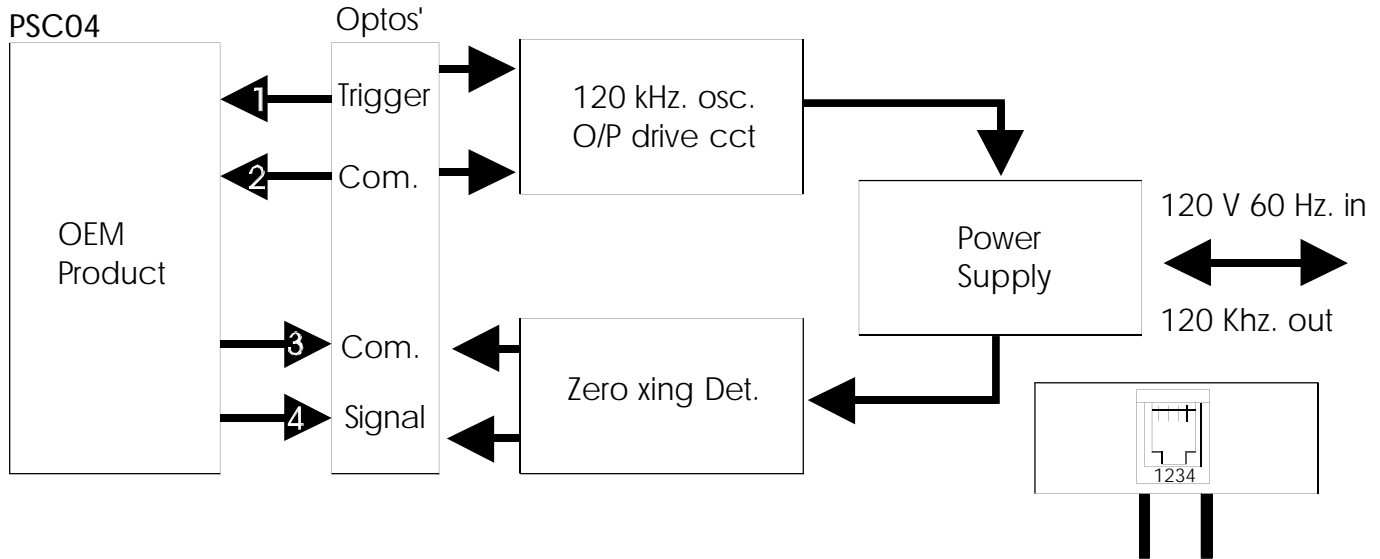

PSC04 Electrical Characteristics at 25Deg C

AC input voltage.	100 - 130VAC 60Hz
Max. voltage between any terminals (1,2,3 and 4)	+/-50V
Storage temperature	-40 to +70Deg C
Operating temperature	-10 to +50Deg C

DC characteristics

Serial data input

Min. Logic '1'	4 V input will sink approx. 2.5 mA
Max. Logic '1'	20 V input will sink approx. 18 mA
Max. Logic '0'	0.8 V input will sink approx. 0.1 mA

(Voltages and currents with respect to terminal 3).

Note: This output is an open collector transistor. Therefore, the logic '1' voltage is quoted as a reference for defining the output leakage current. An output pullup resistor is required to generate a logic level. The pullup can be returned to any voltage up to the +20V with respect to terminal 2.

AC characteristics

RF output to AC power line.	60 mW average into a 5 Ohm load (5 V pk-pk instantaneous).
Carrier frequency	120Khz. +/- 2Khz.
Max. phase delay between zero crossing point of AC power line and zero crossing detect output (either transition).	100 usec.
Max. allowable delay between transitions on zero crossing detect output and serial data input '0' - '1' transition.	50 usec.
Max. delay between serial input envelope '0' - '1' transition and carrier burst reaching 90% level.	50 usec.
Width of X-10 PRO envelope	1 ms + 100 us - 50 us
Isolation voltage	2500 V r.m.s. 60 Hz for 1 min.

PSC05 Electrical Characteristics at 25Deg C

AC input voltage.	100 - 130VAC 60Hz
Max. voltage between any terminals (1,2,3 and 4)	+/-50V
Storage temperature	-40 to +70Deg C
Operating temperature	-10 to +50Deg C

DC characteristics

Serial data input

Min. Logic '1'	4 V input will sink approx. 2.5 mA
Max. Logic '1'	20 V input will sink approx. 18 mA
Max. Logic '0'	0.8 V input will sink approx. 0.1 mA

(Voltages and currents with respect to terminal 2).

Note: This output is an open collector transistor. Therefore, the logic '1' voltage is quoted as a reference for defining the output leakage current. An output pullup resistor is required to generate a logic level. The pullup can be returned to any voltage up to the +20V with respect to terminal 2.

AC characteristics

RF output to AC power line.	60 mW average into a 5 Ohm load (5Vpk-pk instantaneous).
Carrier frequency	120Khz. +/- 2Khz.
Max. phase delay between zero crossing point of AC power line and zero crossing detect output (either transition).	100 usec.
Max. allowable delay between transitions on zero crossing detect output and serial data input '0' - '1' transition.	50 usec.
Max. delay between serial input envelope '0' - '1' transition and carrier burst reaching 90% level.	50 usec.
Width of X-10 PRO envelope	1 ms + 100 us - 50 us
Isolation voltage	2500 V r.m.s. 60 Hz for 1 min.

PSC04 Complete Schematic Diagram

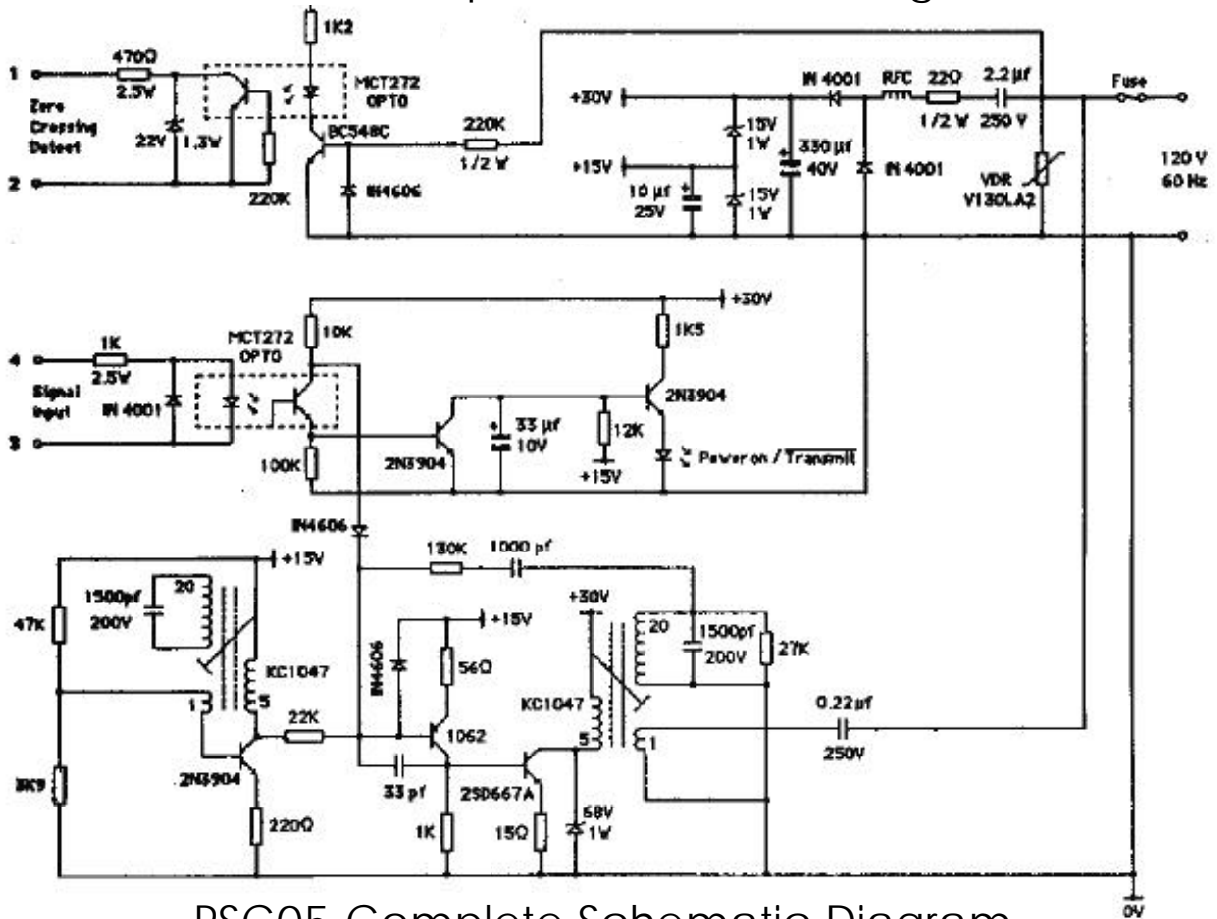

PSC05 Complete Schematic Diagram

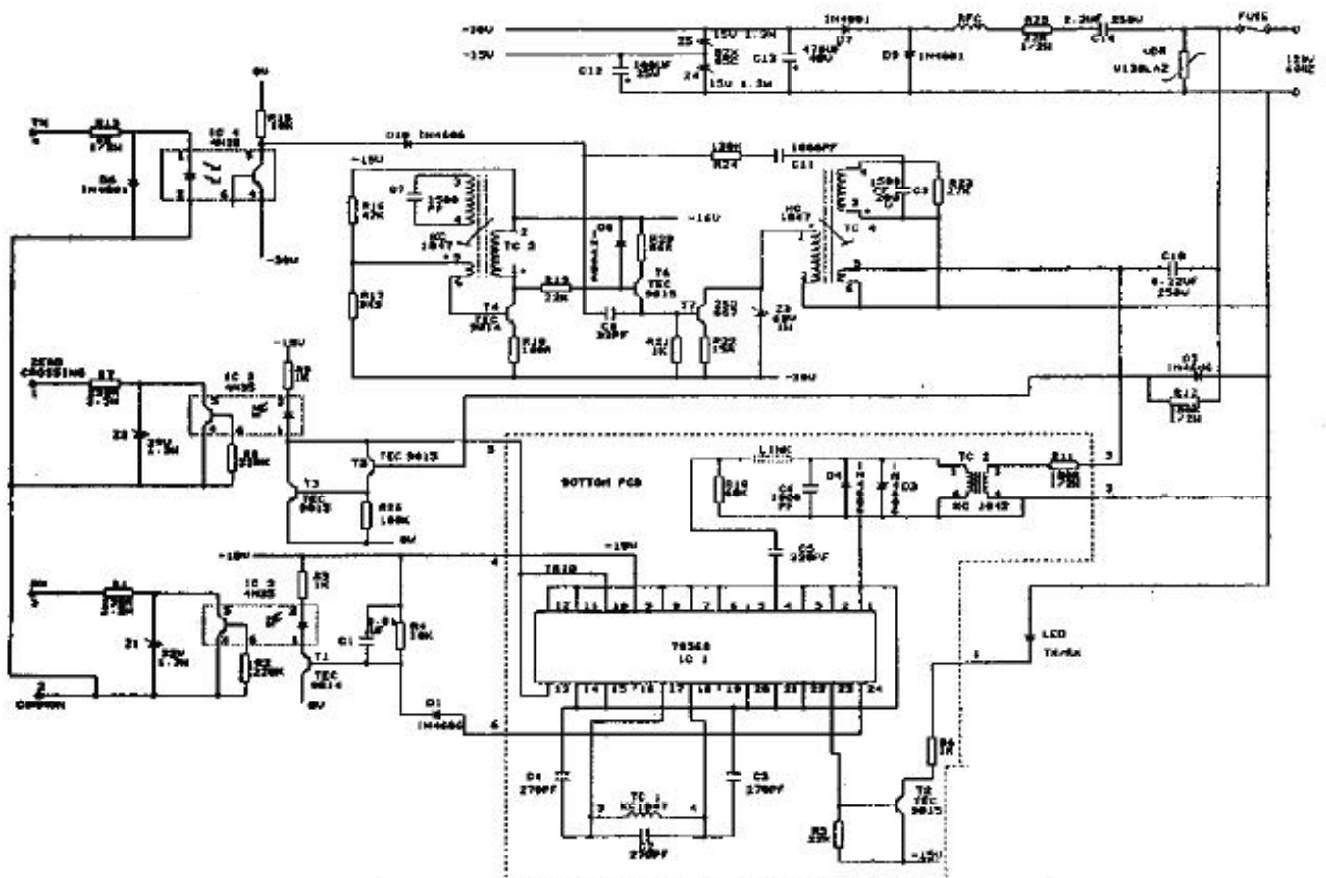

Typical OEM Connection Diagram

